

TORQUE AMPLIFIERS TYPE UVM... - Series 2



The M+S Hydraulic UVM Torque Amplifiers amplify the applied torque to the control shaft and thus ease the running of various transport vehicles such as:

- agricultural and wood working machines;
- road rollers and road cleaning machines;
- fork-lift trucks and construction machinery;

The totally transferred power in terms of output torque is up to 1,1 kW.

The UVM torque amplifiers with their simple design, consisted of a pump and an amplifier, ensure 40 times higher output torque than the applied one. The amplifying is achieved as follows; by rotating the input shaft to the left or right the spool and the bushing are displaced, and the hydraulic flow enters the system turning the gerotor set, which transfers the already amplified torque to the output shaft.

One advantage of the UVM torque amplifier is that it allows manual steering in cases of engine (pump) failure.

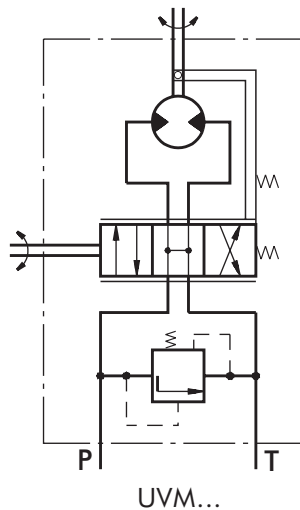

SPECIFICATION DATA

Parameters	Type	
	UVM 100	UVM 160
Displacement [cm ³ /rev]	99,0	158,4
Rated Flow [l/min]	10	16
Rated Pressure* [bar]	70	70
Input Torque [Nm]	3,5...5	3,5...5
Max. Input Torque [Nm]	20	20
Torque Output at 70 bar. [Nm]	80	120
Pressure Drop between P and T at Rated Flow, [bar]	1 ... 2	1,6...2,5
Max. Speed of Rotation at Rated Flow and Pressure [r/min]	100	100
Max. Continuous Pressure in Line T [bar]	20	20
Weight, avg. [kg]	5,8	6,2

* Pressure Settings are at Rated Flow (as in the table) and viscosity 21 mm²/s (50° C).

DIMENSIONS AND MOUNTING DATA

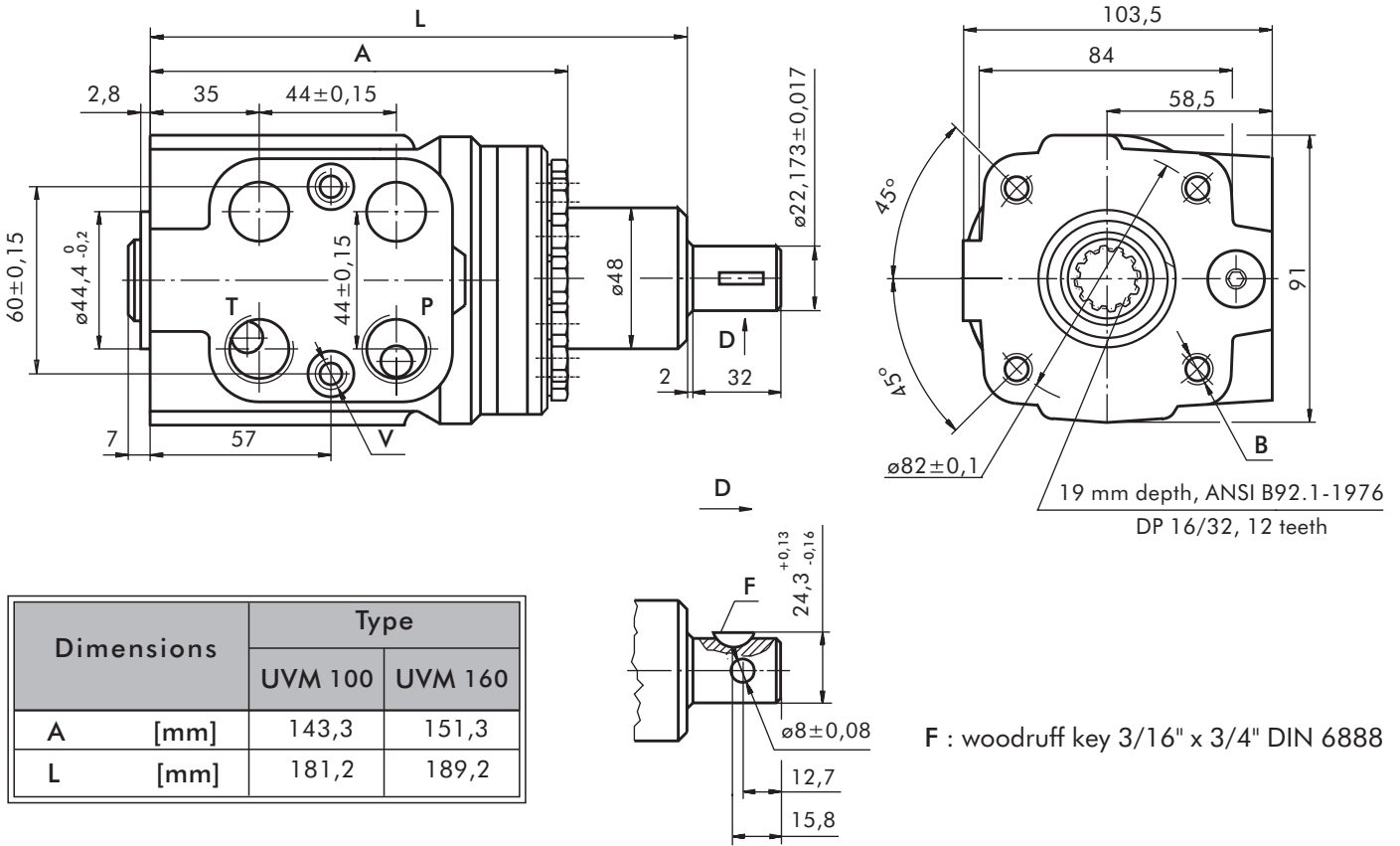

Dimensions	Type	
	UVM 100	UVM 160
A [mm]	143,3	151,3
L [mm]	181,2	189,2

code	Ports - P, T Thread	Column Mounting Thread - B	Port Mounting Thread - V
-	G1/2 17 mm depth	4 x M10 18 mm depth	2 x M10x1 16 mm depth
A	3/4 - 16 UNF O-ring 17 mm depth	4 x 3/8 - 16 UNC 15,7 mm depth	2 x 3/8 - 24 UNF 14,2 mm depth
M	M22x1,5 17 mm depth	4 x M10 18 mm depth	2 x M10x1 16 mm depth

ORDER CODE

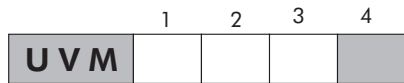

Pos.1 - Displacement code

- 100** - 99,0 [cm³/rev]
- 160** - 158,4 [cm³/rev]

Pos.2 - Ports

- omit - BSPP (ISO 228)
- A** - SAE (ANSI B 1.1 - 1982)
- M** - Metric (ISO 262)

Pos.3 - Option (Paint)*

- omit - No Paint
- P** - Painted
- PC** - Corrosion Protected Paint

Pos.4 - Design Series

- omit - Factory specified

NOTES:

* Colour at customer's request.
The steering units are mangano-phosphatized as standard.