

# HYDRAULIC MOTORS EPRM

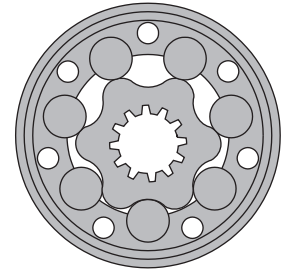

## APPLICATION

- » Conveyors;
- » Feeding mechanism of robots and manipulators;
- » Metal working machines;
- » Textile machines;
- » Machines for agriculture;
- » Food industries;
- » Grass cutting machinery etc.



## CONTENTS

Specification data .....	30 ÷ 33
Function diagrams .....	34 ÷ 38
Permissible shaft Seal Pressure ...	38
Dimensions and mounting .....	39
Wheel motor .....	40
Shaft versions .....	26
Permissible shaft loads .....	27
Order code .....	41

## OPTIONS

- » Model- Spool valve, geroler;
- » Flange and wheel mount;
- » Motor with needle bearing;
- » Side and rear ports;
- » Shafts- straight, splined and tapered;
- » Shaft seal for high and low pressure;
- » Metric and BSPP ports;
- » Other special features.

## GENERAL

Displacement, [cm <sup>3</sup> /rev.]	51,5 ÷ 397
Max. Speed, [RPM]	775 ÷ 150
Max. Torque, [daNm]	10,1 ÷ 61
Max. Output, [kW]	5 ÷ 13
Max. Pressure Drop, [bar]	175 ÷ 70
Max. Oil Flow, [l/min]	40 ÷ 60
Min. Speed, [RPM]	10
Pressure fluid	Mineral based- HLP(DIN 51524) or HM(ISO 6743/4)
Temperature range, [°C]	-30 ÷ 90
Optimal Viscosity range, [mm <sup>2</sup> /s]	20 ÷ 75
Filtration	ISO code 20/16 (Min. recommended fluid filtration of 25 micron)

### Oil flow in drain line

Pressure drop (bar)	Viscosity (mm <sup>2</sup> /s)	Oil flow in drain line (l/min)
100	20	2,5
	35	1,8
140	20	3,5
	35	2,8

### Pressure Losses

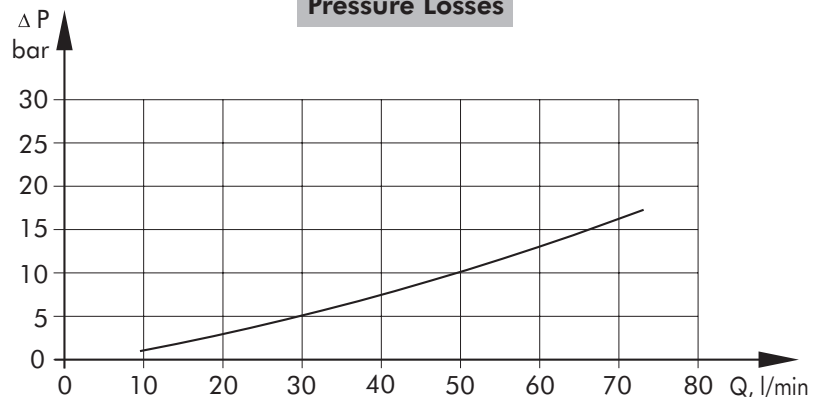

## SPECIFICATION DATA

Type	EPRM 50	EPRMW 50 EPRM 50...B	EPRM 80	EPRMW 80 EPRM 80...B	EPRM 100	EPRMW100 EPRM100...B
Displacement, [cm <sup>3</sup> /u]	51,5	51,5	80,3	80,3	99,8	99,8
Max. Speed, [RPM]	cont.	775	775	750	750	600
	int.*	970	970	940	940	750
Max. Torque [daNm]	cont.	10,1	10,1	19,5	19,5	24
	int.*	13	13	22	22	28
	peak**	17	17	27	27	32
Max. Output, [kW]	cont.	7	7	12,5	12,5	13
	int.*	8,5	8,5	15	15	15
Max. Pressure Drop [bar]	cont.	140	140	175	175	175
	int.*	175	175	200	200	200
	peak**	225	225	225	225	225
Max. Oil Flow [l/min]	cont.	40	40	60	60	60
	int.*	50	50	75	75	75
Max. Inlet Pressure [bar]	cont.	175	175	175	175	175
	int.*	200	200	200	200	200
	peak**	225	225	225	225	225
Max. Return Pressure w/o Drain Line or max. Pressure in Drain Line, [bar]	cont.0-100 RPM	150	100	150	100	150
	cont.100-300 RPM	75	30	75	30	75
	cont.300-600 RPM	50	15	50	15	50
	cont.>600 RPM	20	-	20	-	20
	int.* 0-max. RPM	150	100	150	100	150
Max. Return Pressure with Drain Line [bar]	cont.	175	175	175	175	175
	int.*	200	200	200	200	200
	peak**	225	225	225	225	225
Max. Starting Pressure with Unloaded Shaft, [bar]	10	10	10	10	10	10
Min. Starting Torque [daNm]	at max. press. drop cont.	8	8	15	15	20
	at max. press. drop int.*	10	10	17	17	23
Min. Speed***, [RPM]	10	10	10	10	10	10
Weight, avg., [kg]	EPRM (F)	6,8	6,9	6,9	7,0	7,2
	EPRMW	-	10,4	-	10,5	-
	EPRMQ	6,2	-	6,3	-	6,6

\* Intermittent operation: the permissible values may occur for max. 10% of every minute.

\*\* Peak load: the permissible values may occur for max. 1% for every minute.

\*\*\* For speeds of 10 RPM or lower, consult factory or your regional manager.

1. Intermittent speed and intermittent pressure drop must not occur simultaneously!
2. Recommended filtration is per ISO cleanliness code 20/16. A nominal filtration of 25 micron or better.
3. Recommended using a premium quality, anti-wear type mineral based hydraulic oil HLP(DIN51524) or HM (ISO 6743/4).  
If using synthetic fluids consult the factory for alternative seal materials.
4. Recommended minimum oil viscosity 13 mm<sup>2</sup>/s at operating temperatures.
5. Recommended maximum system operating temperature - 82°C.
6. To assure optimum motor life fill with fluid prior to loading and run at moderate load and speed for 10-15 min.

## SPECIFICATION DATA (continued)

Type	EPRM 125	EPRMW100 EPRM100...B	EPRM 160	EPRMW160 EPRM160...B	EPRM 200	EPRMW200 EPRM200...B	
Displacement, [cm <sup>3</sup> /u]	125,7	125,7	159,6	159,6	199,8	199,8	
Max. Speed, [RPM]	cont.	475	475	375	375	300	300
	int.*	600	600	470	470	375	375
Max. Torque [daNm]	cont.	30	30	39	39	38,5	45
	int.*	34	34	43	43	46	50
	peak**	37	37	46	46	56	56
Max. Output, [kW]	cont.	12,5	12,5	11,5	11,5	9	11
	int.*	14,5	14,5	14	14	11,5	13
Max. Pressure Drop [bar]	cont.	175	175	175	175	140	175
	int.*	200	200	200	200	175	200
	peak**	225	225	225	225	225	225
Max. Oil Flow [l/min]	cont.	60	60	60	60	60	60
	int.*	75	75	75	75	75	75
Max. Inlet Pressure [bar]	cont.	175	175	175	175	175	175
	int.*	200	200	200	200	200	200
	peak**	225	225	225	225	225	225
Max. Return Pressure w/o Drain Line or max. Pressure in Drain Line, [bar]	cont.0-100 RPM	150	100	150	100	150	100
	cont.100-300 RPM	75	30	75	30	75	30
	cont.300-600 RPM	50	15	50	15	50	15
	cont.>600 RPM	-	-	-	-	-	-
	int.* 0-max. RPM	150	100	150	100	150	100
Max. Return Pressure with Drain Line [bar]	cont.	175	175	175	175	175	175
	int.*	200	200	200	200	200	200
	peak**	225	225	225	225	225	225
Max. Starting Pressure with Unloaded Shaft, [bar]	9	9	7	7	5	5	
Min. Starting Torque [daNm]	at max. press. drop cont.	25	25	32	32	33	41
	at max. press. drop int.*	28	28	37	37	40	46
Min. Speed***, [RPM]	10	10	10	10	10	10	
Weight, avg., [kg]	EPRM (F)	7,3	7,4	7,5	7,6	8	8,1
	EPRMW	-	10,8	-	11,1	-	11,6
	EPRMQ	6,8		7,6		7,2	

\* Intermittent operation: the permissible values may occur for max. 10% of every minute.

\*\* Peak load: the permissible values may occur for max. 1% for every minute.

\*\*\* For speeds of 10 RPM or lower, consult factory or your regional manager.

1. Intermittent speed and intermittent pressure drop must not occur simultaneously!
2. Recommended filtration is per ISO cleanliness code 20/16. A nominal filtration of 25 micron or better.
3. Recommended using a premium quality, anti-wear type mineral based hydraulic oil HLP(DIN51524) or HM (ISO 6743/4).  
If using synthetic fluids consult the factory for alternative seal materials.
4. Recommended minimum oil viscosity 13 mm<sup>2</sup>/s at operating temperatures.
5. Recommended maximum system operating temperature - 82°C.
6. To assure optimum motor life fill with fluid prior to loading and run at moderate load and speed for 10-15 min.

## SPECIFICATION DATA (continued)

Type	EPRM 250	EPRMW250 EPRM250...B	EPRM 315	EPRMW315 EPRM315...B	EPRM 400	EPRMW400 EPRM400...B
Displacement, [cm <sup>3</sup> /u]	250,1	250,1	315,7	315,7	397	397
Max. Speed, [RPM]	cont.	240	240	190	190	150
	int.*	300	300	240	240	190
Max. Torque [daNm]	cont.	39	54	39	55	38
	int.*	58	61	57	63	60
	peak**	71	71	83	83	87
Max. Output, [kW]	cont.	6,5	10	6	9	4,8
	int.*	10,5	12	9,6	11	8,8
Max. Pressure Drop [bar]	cont.	110	175	90	135	70
	int.*	175	200	140	160	115
	peak**	225	225	210	210	175
Max. Oil Flow [l/min]	cont.	60	60	60	60	60
	int.*	75	75	75	75	75
Max. Inlet Pressure [bar]	cont.	175	175	175	175	175
	int.*	200	200	200	200	200
	peak**	225	225	225	225	225
Max. Return Pressure w/o Drain Line or max. Pressure in Drain Line, [bar]	cont.0-100 RPM	150	100	150	100	150
	cont.100-300 RPM	75	30	75	30	75
	cont.300-600 RPM	-	-	-	-	-
	int.* 0-max. RPM	150	100	150	100	150
Max. Return Pressure with Drain Line [bar]	cont.	175	175	175	175	175
	int.*	200	200	200	200	200
	peak**	225	225	225	225	225
Max. Starting Pressure with Unloaded Shaft, [bar]	4	4	3	3	3	3
Min. Starting Torque [daNm]	at max. press. drop cont.	31	50	33	50	30
	at max. press. drop int.*	48	55	58	66	50
Min. Speed***, [RPM]	10	10	10	10	10	10
Weight, avg., [kg]	EPRM (F)	8,4	8,5	9,1	9,2	9,8
	EPRMW	-	12,1	-	12,6	-
	EPRMQ	7,8		8,6		9,3

\* Intermittent operation: the permissible values may occur for max. 10% of every minute.

\*\* Peak load: the permissible values may occur for max. 1% for every minute.

\*\*\* For speeds of 10 RPM or lower, consult factory or your regional manager.

1. Intermittent speed and intermittent pressure drop must not occur simultaneously!
2. Recommended filtration is per ISO cleanliness code 20/16. A nominal filtration of 25 micron or better.
3. Recommended using a premium quality, anti-wear type mineral based hydraulic oil HLP(DIN51524) or HM (ISO 6743/4).  
If using synthetic fluids consult the factory for alternative seal materials.
4. Recommended minimum oil viscosity 13 mm<sup>2</sup>/s at operating temperatures.
5. Recommended maximum system operating temperature - 82°C.
6. To assure optimum motor life fill with fluid prior to loading and run at moderate load and speed for 10-15 min.

### SPECIFICATION DATA for EPRM...LSV

**Low Speed Valve (LSV)** "LSV" Series hydraulic motors have been designed to operate with normal pressure drop and to ensure smooth run at low speed (up to 200 RPM), as the best security for operation is guaranteed at frequency of rotation  $20 \div 50$  RPM . They have an increased starting pressure drop and are not recommended for using at pressure less than 40 bar.

Look at specification data for hydraulic motors standard version. The modification concerns only the following parameters: maximum speed , maximum output, maximum Oil flow and maximum starting pressure.

Type		EPRM 50	EPRM 80	EPRM 100	EPRM 125	EPRM 160	EPRM 200	EPRM 250	EPRM 315	EPRM 400
<b>Max. Speed</b> [RPM]	Cont.	200	200	200	200	200	200	160	126	100
	Int.*	250	250	250	250	250	250	200	158	126
<b>Max. Output</b> [kW]	Cont.	2	4,0	5,0	6,2	7,0	6,8	6,2	5,8	5,2
	Int.*	3	5,7	7,3	8,5	8,8	8,3	7,8	7,6	6,8
<b>Max. Oil Flow</b> [lpm]	Cont.	13	23	26	33	40	40	40	40	40
	Int.*	16	31	34	45	50	50	50	50	50
<b>Max. Starting Pressure with unloaded Shaft, [bar]</b>		20	20	20	20	15	15	15	12	12

### SPECIFICATION DATA for EPRM...LL

**Low Leakage (LL)** "LL" Series hydraulic motors have been designed to operate at the whole standard range of working conditions (pressure drop and frequency of rotation ) , but with considerable decreased volumetric losses in the drainage ports. Their main purpose is to operate as series-connected motors in hydraulic systems.

For this version is permissible decreasing of the maximal torque with up to 5% (at middle speed) and up to 10% (at high speed) in comparison to the standard versions of motors.

Look at specification data for hydraulic motors series EPRM standard version. The modification concerns only the parameters: maximum torque, maximum output, minimum starting torque.

Type		EPRM 50	EPRM 80	EPRM 100	EPRM 125	EPRM 160	EPRM 200	EPRM 250	EPRM 315	EPRM 400
<b>Max. Torque</b> [daNm]	Cont.	9,6	18,5	22,8	28,5	37,1	42,8	51,3	52,2	58,0
	Int.*	12,4	20,9	26,6	32,3	40,9	47,5	58,0	60,0	65,6
<b>Max. Output</b> [kW]	Cont.	9,0	12,3	12,8	12,4	11,4	10,9	9,9	8,9	7,7
	Int.*	11,9	14,8	14,8	14,3	13,8	12,8	11,8	10,9	10,5
<b>Max. Pressure Drop</b> [bar]	Cont.	140	175	175	175	175	175	175	135	115
	Int.*	175	200	200	200	200	200	200	160	140
<b>Min. Starting Torque</b> [daNm]	Cont.	7,6	14,2	19,0	23,8	30,4	39,0	47,5	47,5	46,5
	Int.*	9,5	16,2	21,8	26,6	35,2	43,7	52,2	62,7	58,0

### SPECIFICATION DATA for EPRM...FR

**Free Running** version "FR" these are the hydraulic motors with reduced mechanical losses , for wich at disengaged condition / unconnected with driving mechanism / the rotation of the shaft could be realized by means of small torque. This advantage is especially useful at operating with high frequencies of rotation /over than  $300 \text{ min}^{-1}$ / and low pressure drop , which is inbred for types with displacements of up to  $200 \text{ cm}^3$ . It is normal for these for the different condition of operation to have high torque , as well as high volume losses: the values of the volumetric efficiency are lower ( up to 5 % for middle and up to 10% for high values of the pressure drop ) , than these of the normal versions. That's why the recommended operating for "FR version is for applications with pressure drop up to 100 bar.

Additional advantages of "FR" version are prolonging of the life of the hydraulic motors at high frequencies of rotation, as well as the possibility to use them in systems with big variation of the loading.

Look at specification data for hydraulic motors series EPRM standard version. Only the parameter Starting Pressure is modified.

Type	EPRM 50	EPRM 80	EPRM 100	EPRM 125	EPRM 160	EPRM 200
<b>Max. Starting Pressure with Unloaded Shaft, [bar]</b>	8	8	8	7,5	5,5	4

**DIMENSIONS AND MOUNTING DATA**

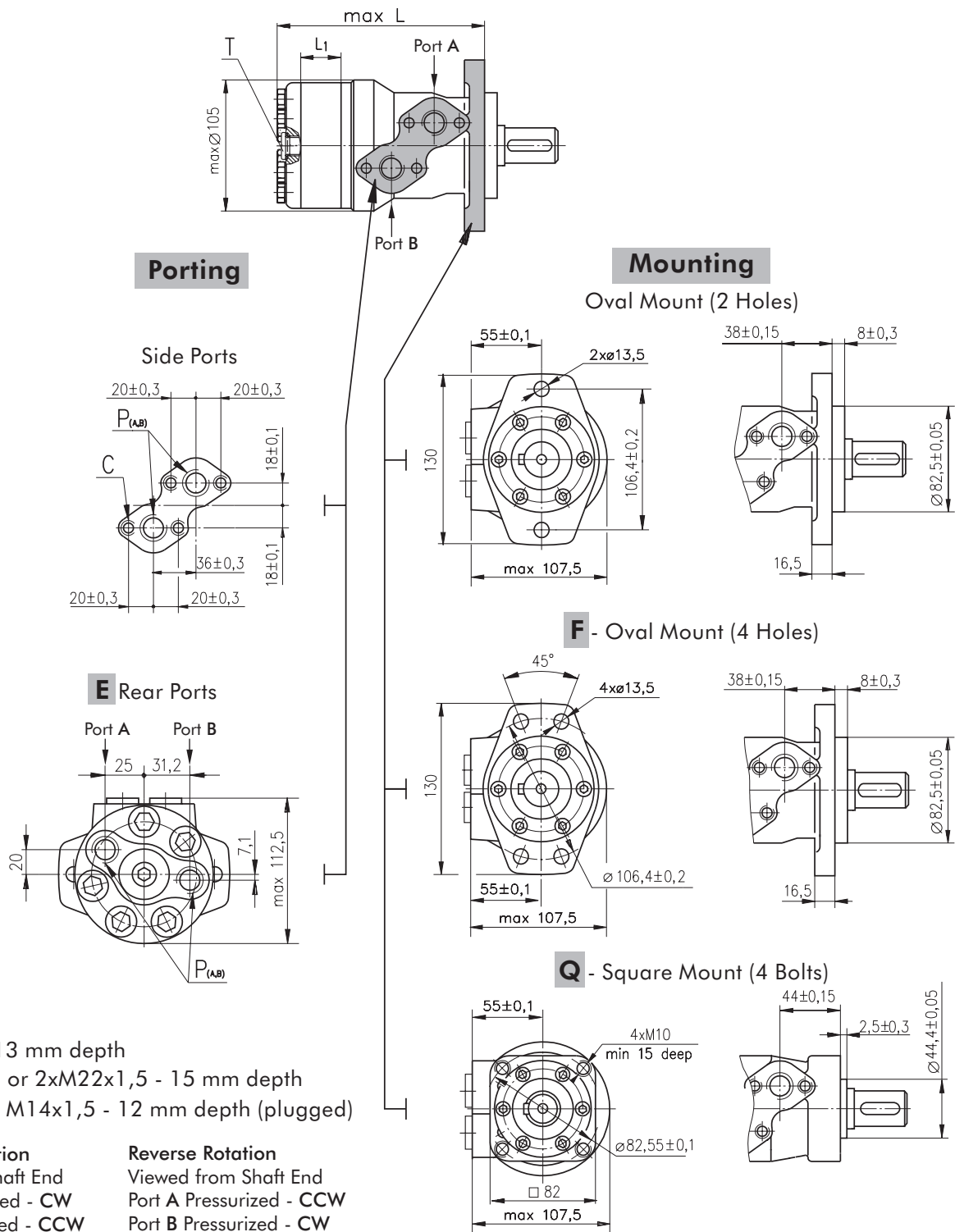

**C** : 4xM8 - 13 mm depth  
**P<sub>(A,B)</sub>** : 2xG1/2 or 2xM22x1,5 - 15 mm depth  
**T** : G1/4 or M14x1,5 - 12 mm depth (plugged)

**Standard Rotation**  
 Viewed from Shaft End  
 Port A Pressurized - CW  
 Port B Pressurized - CCW

**Reverse Rotation**  
 Viewed from Shaft End  
 Port A Pressurized - CCW  
 Port B Pressurized - CW

Type	L, mm	Type	L, mm	Type	L, mm	Type	L, mm	L <sub>1</sub> , mm
EPRM(F) 50	138,0	EPRMQ 50	143,5	EPRM(F)E 50	157,5	EPRMQE 50	163,5	9,0
EPRM(F) 80	143,0	EPRMQ 80	148,5	EPRM(F)E 80	162,5	EPRMQE 80	168,5	14,0
EPRM(F) 100	146,0	EPRMQ 100	152,0	EPRM(F)E 100	165,5	EPRMQE 100	171,5	17,4
EPRM(F) 125	150,5	EPRMQ 125	156,5	EPRM(F)E 125	170,0	EPRMQE 125	176,0	21,8
EPRM(F) 160	156,5	EPRMQ 160	162,5	EPRM(F)E 160	176,0	EPRMQE 160	182,0	27,8
EPRM(F) 200	163,5	EPRMQ 200	169,5	EPRM(F)E 200	183,0	EPRMQE 200	189,0	34,8
EPRM(F) 250	172,0	EPRMQ 250	179,0	EPRM(F)E 250	192,0	EPRMQE 250	198,0	43,5
EPRM(F) 315	183,0	EPRMQ 315	189,0	EPRM(F)E 315	204,0	EPRMQE 315	210,0	54,8
EPRM(F) 400	198,0	EPRMQ 400	204,0	EPRM(F)E 400	218,0	EPRMQE 400	224,0	69,4

# HYDRAULIC MOTORS EPML



## APPLICATION

- » Conveyors;
- » Feeding mechanism of robots and manipulators;
- » Metal working machines;
- » Textile machines;
- » Machines for agriculture;
- » Food industries;
- » Mining machinery etc.

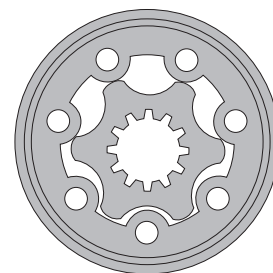

## CONTENTS

Specification data .....	43
Function diagrams .....	18÷22
Dimensions and mounting ...	44
Shaft extensions .....	45
Permissible shaft loads .....	45
Order code .....	46

## OPTIONS

- » Model- Spool valve, gerotor;
- » Antifriction conical bearings;
- » Flange mount;
- » Shafts- straight, splined and tapered;
- » Metric and BSPP ports;
- » Other special features.

## GENERAL

Displacement, [cm <sup>3</sup> /rev.]	49,5 ÷ 396
Max. Speed, [RPM]	1210 ÷ 150
Max. Torque, [daNm]	9,4 ÷ 50
Max. Output, [kW]	9,9 ÷ 11,7
Max. Pressure Drop, [bar]	140 ÷ 95
Max. Oil Flow, [l/min]	60
Min. Speed, [RPM]	10
Permissible Shaft Loads, [daN]	P <sub>rad</sub> = 1500; P <sub>a</sub> = 800
Pressure fluid	Mineral based- HLP(DIN 51524) or HM(ISO 6743/4)
Temperature range, [°C]	-30 ÷ 90
Optimal Viscosity range, [mm <sup>2</sup> /s]	20 ÷ 75
Filtration	ISO code 20/16 (Min. recommended fluid filtration of 25 micron)

**Oil flow in drain line**

Pressure drop (bar)	Viscosity (mm <sup>2</sup> /s)	Oil flow in drain line (l/min)
100	20	2,5
	35	1,8
140	20	3,5
	35	2,8

**Pressure Losses**

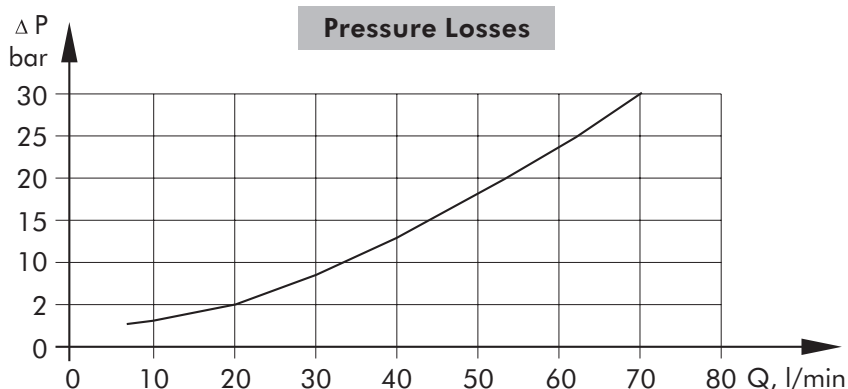

## SPECIFICATION DATA

Type		EPML 50	EPML 80	EPML 100	EPML 125	EPML 160	EPML 200	EPML 250	EPML 315	EPML 400
<b>Displacement, [cm.<sup>3</sup>/rev.]</b>		49,5	79,2	99	123,8	158,4	198	247,5	316,8	396
<b>Max. Speed, [RPM]</b>	Cont.	1210	755	605	485	378	303	242	190	150
	Int.*	1515	945	755	605	472	378	303	236	189
<b>Max. Torque [daNm]</b>	Cont.	9,4	15,1	19,3	23,7	31,3	36,6	47,0	48,6	50,0
	Int.*	11,9	19,5	23,7	29,8	37,8	45,6	58,3	56,0	59,0
	Peak**	14,0	22,0	27,0	36,5	42	53,0	67,0	85,0	85,4
<b>Max. Output [kW]</b>	Cont.	9,9	9,9	9,9	9,9	11,7	10,3	9,8	7,6	6,6
	Int.*	12,5	12,5	12,5	12,5	12,5	15,5	17,5	8,2	9,2
<b>Max. Pressure Drop [bar]</b>	Cont.	140	140	140	140	140	140	140	120	95
	Int.*	175	175	175	175	175	175	175	140	115
	Peak**	225	225	225	225	225	225	225	225	180
<b>Max. Oil Flow [l/min]</b>	Cont.	60	60	60	60	60	60	60	60	60
	Int.*	75	75	75	75	75	75	75	75	75
<b>Max. Inlet Pressure [bar]</b>	Cont.	175	175	175	175	175	175	175	175	175
	Int.*	200	200	200	200	200	200	200	200	200
	Peak**	225	225	225	225	225	225	225	225	225
<b>Max. Return Pressure without Drain Line or Max. Pressure in Drain Line, [bar]</b>	Cont. 0-100 RPM	100	100	100	100	100	100	100	100	100
	Cont. 100-300 RPM	50	50	50	50	50	50	50	50	50
	Cont. 300-600 RPM	25	25	25	25	25	25	25	25	25
	Cont. >600 RPM	15	15	15	15	15	15	15	15	15
<b>Max. Return Pressure with Drain Line [bar]</b>	Int.* 0-max. RPM	100	100	100	100	100	100	100	100	100
	Cont.	175	175	175	175	175	175	175	175	175
	Int.*	200	200	200	200	200	200	200	200	200
<b>Max. Starting Pressure with Unloaded Shaft, [bar]</b>	Cont.	10	10	10	9	8	7	6	5	5
	Int.*	10	10	10	10	10	10	10	10	10
<b>Min. Starting Torque [daNm]</b>		7,7	14,0	16,8	21,0	28,0	34,6	44,0	46,0	50,0
<b>Min. Speed***, [RPM]</b>		10	10	10	10	10	10	10	10	10
<b>Weight, [kg]</b>		8,4	8,5	8,8	8,9	9,1	9,5	10,0	10,7	11,4

\* Intermittent operation: the permissible values may occur for max. 10% of every minute.

\*\* Peak load: the permissible values may occur for max. 1% of every minute.

\*\*\* For speeds of 10 RPM or lower, consult factory or your regional manager.

1. Intermittent speed and intermittent pressure drop must not occur simultaneously.
2. Recommended filtration is per ISO cleanliness code 20/16. A nominal filtration of 25 micron or better.
3. Recommended using a premium quality, anti-wear type mineral based hydraulic oil HLP(DIN51524) or HM (ISO 6743/4).  
If using synthetic fluids consult the factory for alternative seal materials.
4. Recommended minimum oil viscosity 13 mm<sup>2</sup>/s at operating temperatures.
5. Recommended maximum system operating temperature is 82°C.
6. To assure optimum motor life fill with fluid prior to loading and run at moderate load and speed for 10-15 minutes.

**DIMENSIONS AND MOUNTING DATA**

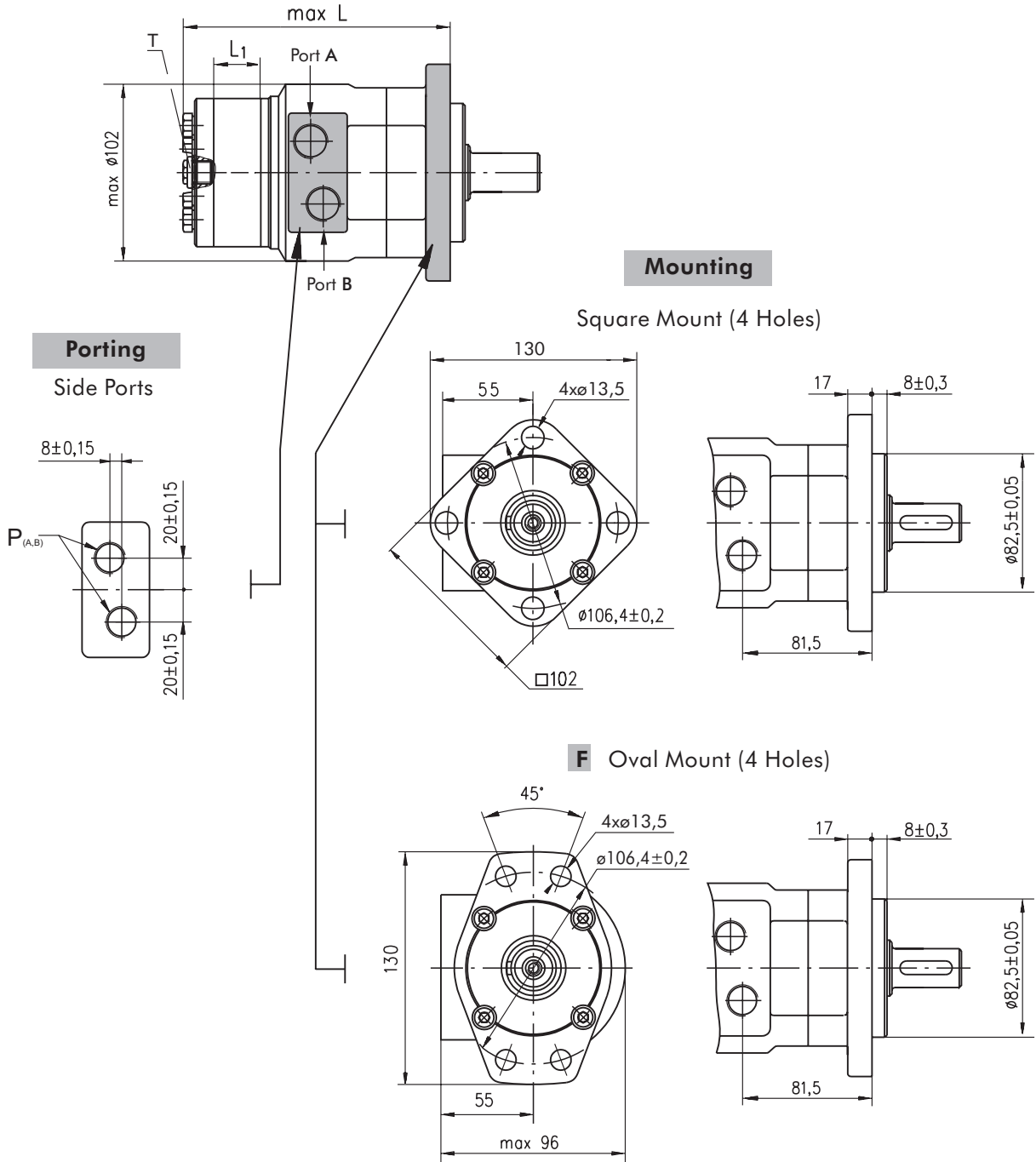

Type	L, mm	L1, mm
EPML 50	148	6,67
EPML 80	152	10,67
EPML 100	155	13,33
EPML 125	158	16,67
EPML 160	163	21,33
EPML 200	168	26,67
EPML 250	175	33,33
EPML 315	184	42,67
EPML 400	195	53,33

**P<sub>(A, B)</sub>**: 2xG1/2 or 2xM22x1,5 - 15 mm depth  
**T** : G1/4 or M14x1,5 - 12 mm depth (plugged)

<b>Standard Rotation</b>	<b>Reverse Rotation</b>
Viewed from Shaft End	Viewed from Shaft End
Port A Pressurized - CW	Port A Pressurized - CCW
Port B Pressurized - CCW	Port B Pressurized - CW